

Chain Couplings

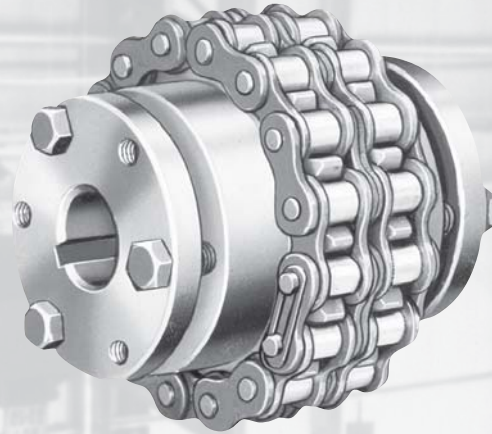

Index:

	Page
Covers for Chain Couplings.....	188
Replacement Chain	188
Horsepower Ratings	189
Load Classifications.....	190
Service Factors.....	190
How to Order	190



CHAIN COUPLING COVERS

Chain Coupling Covers extend the life of the couplings by providing continuous lubrication and protection from abrasive and corrosive conditions. They are fitted with Neoprene seals, standard 1/8" pipe plugs and "Nyloc" cap screws, and fit all chain couplings — finished bore, minimum bore, split taper bushing type and taper bore bushing type.

CAUTION - Chain Coupling Covers should not be operated at speeds exceeding 5000 FPM rim speed.

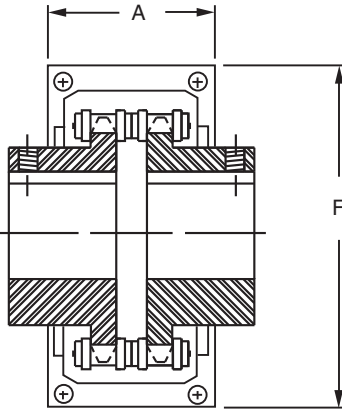

Table No. 7 Aluminum Covers

Cover Part No.*	Coupling Ref. No.	Dimensions (inches)		Wt. Lbs.	Accessory Kit**	
		A	F		Part No.	Wt. Lbs.
AL40	C4012	2	4	0.75	AL4012AK	0.2
	C4016				AL4016AK	0.2
AL4020	C4020	2 3/8	5 1/8	1.25	AL5020AK	0.3
	C5016				AL5016AK	0.3
AL50	C5018	2 3/8	5 1/8	1.25	AL5018AK	0.3
	C6018				AL6018AK	0.5
AL60	C6020	2 15/16	6 3/8	2.25	AL6020AK	0.5
	C8018				AL8018AK	0.7
AL80	C8020	4	8 3/16	4.50	AL8020AK	0.7
	C10018				AL10018AK	1.0
AL100	C10020	5 1/4	10 1/8	12.25	AL10020AK	1.0

* Cover includes 2 cover halves, 4 seals (except 2 seals for AL4020), gaskets and all necessary hardware for installation.

** Accessory Kit includes 2 seals for specified hub, 2 gaskets and all necessary hardware for reinstallation.



Chains for Couplings
Table No. 8

Coupling Ref. No.	Chain Part No.	Wt. Lbs.
C4012	C4012	0.4
C4016	C4016	0.5
C4020	C4020	0.7
C5016	C5016	1.2
C5018	C5018	1.3
C6018	C6018	2.2
C6020	C6020	2.6
C8018	C8018	5.3
C8020	C8020	5.9
C10018	C10018	9.8
C10020	C10020	10.9



REPLACEMENT CHAIN

Replacement chains of correct length for each stock coupling are available from stock, individually packaged and complete with connecting links.

Horsepower Ratings for Finished Bore and Minimum Bore Chain Couplings

Table No. 9



Coupling Size	Below 50 RPM Max. Torque (ft.-lbs.)	Horsepower at Indicated Speeds											Max. RPM with Cover*
		50	100	200	300	400	600	900	1200	1500	1800	3600	
C4012	113	1.08	2.15	3.43	4.52	5.57	7.56	10.45	13.10	15.70	18.20	33.10	5,000
C4016	200	1.90	3.81	6.07	8.00	9.86	13.40	18.50	23.20	27.80	32.20	58.50	5,000
C4020	308	2.93	5.86	9.26	12.32	15.01	20.41	28.50	35.18	42.22	49.61	88.67	4,000
C5016	384	3.66	7.32	11.70	15.35	18.90	25.70	35.53	44.50	53.30	61.90	112.00	4,000
C5018	525	5.00	10.00	15.00	21.00	25.00	33.00	48.58	57.00	67.00	79.00	145.00	4,000
C6018	910	8.70	17.30	27.60	36.38	44.90	60.90	84.20	105.00	126.00	147.00		3,000
C6020	1050	10.00	23.00	36.00	41.98	58.00	79.00	97.16	135.00	165.00	192.00		3,000
C8018	2027	19.30	38.60	61.40	81.05	99.80	135.00	187.57	234.00	281.00	326.00		2,000
C8020	2625	25.00	50.00	80.00	104.96	130.00	175.00	242.90	302.00	365.00	430.00		2,000
C10018	3644	34.70	69.40	111.00	145.70	180.00	244.00	337.30	422.00	506.00	587.00		1,800
C10020	4495	42.80	85.60	136.00	179.73	221.00	300.00	415.95	517.00	621.00	708.00		1,800

For maximum service life, a cover with proper lubrication is required for couplings selected with ratings to the right of the heavy line. Shaft and key stresses have not been considered in the above ratings.

***WARNING - Couplings with covers must not be operated beyond this speed.**

Horsepower Ratings for Chain Couplings with SPLIT TAPER Bushings

Table No. 10



Coupling Size	Below 50 RPM Max. Torque (ft.-lbs.)	Horsepower at Indicated Speeds											Max. RPM with Cover*
		50	100	200	300	400	600	900	1200	1500	1800	3600	
C4020XH	220	2.09	4.19	6.61	8.79	10.72	14.57	20.36	25.13	30.16	35.43	63.33	4,000
C5016XH	220	2.09	4.19	6.61	8.79	10.72	14.57	30.36	25.13	30.16	35.43	63.33	4,000
C5018XP	525	5.00	10.00	15.00	21.00	25.00	33.00	48.58	57.00	67.00	79.00	145.00	4,000
C6018XP	708	6.74	13.48	21.29	28.30	34.51	46.91	65.51	80.88	97.06	114.04		3,000
C6020XB	708	6.74	13.48	21.29	28.30	34.51	46.91	65.51	80.88	97.06	114.04		3,000
C8018XQ	1750	16.66	33.32	52.64	69.97	85.30	115.95	161.93	199.92	239.90	281.89		2,000
C10018XR	2750	26.18	52.36	82.73	109.95	134.04	182.21	254.47	314.16	376.99	442.97		1,800

For maximum service life, a cover with proper lubrication is required for couplings selected with ratings to the right of the heavy line.

***WARNING - Couplings with covers must not be operated beyond this speed.**

Horsepower Ratings for Chain Couplings with Taper Bore Bushings

Table No. 10



Coupling Size	Below 50 RPM Max. Torque (ft.-lbs.)	Horsepower at Indicated Speeds											Max. RPM with Cover*
		50	100	200	300	400	600	900	1200	1500	1800	3600	
C40TB16	108	1.02	2.05	3.24	4.31	5.26	7.15	9.99	12.33	14.80	17.39	31.09	5,000
C50TB18	358	3.40	6.81	10.77	14.31	17.45	23.72	33.12	40.89	49.07	57.66	103.06	4,000
C60TB20	595	5.66	11.32	17.89	23.79	29.00	39.42	55.05	67.97	81.56	95.84		3,000
C80TB20	2000	19.04	38.08	60.16	79.96	97.48	132.52	185.07	228.48	274.18	322.16		2,000
C100TB20	3733	35.53	71.07	112.30	149.26	181.95	247.35	345.43	426.46	511.75	601.31		1,800

For maximum service life, a cover with proper lubrication is required for couplings selected with ratings to the right of the heavy line.

***WARNING - Couplings with covers must not be operated beyond this speed.**

Table No. 12 Load Classifications

CLASS E Even Load	CLASS U Uneven Load	CLASS H Heavy Shock Load
Agitators for liquids Blowers, centrifugal Conveyor, belt or chain smoothly loaded Cranes Elevator, smoothly loaded Fans, centrifugal Generators Line Shafts, even load Machines, uniform load, non-reversing Pumps, centrifugal Screens, uniformly fed Worm gear speed reducers	Beaters Compressors, centrifugal Conveyors, pulsating load Grinders, pulp Hoists Kilns and dryers Line shafts, uneven load Machines, non-reversing Mills, ball, blooming, pebble, tube Pumps, reciprocating	Boat propellers Compressors, reciprocating Crushers Feeders, reciprocating Machines, reversing or impact loads Mills, hammer Oil Well Pumping Units Presses Pumps, simplex or duplex, reciprocating Refuse hogs

Table No. 13 Service Factors

Class	Characteristics of Driven Unit	Source of Power		
		Electric Motor or Steam Turbine	Steam Engine or Gasoline Engine 4 or more Cyl.	Diesel or Gas Engine
E	Even load - 8 hour/day service* Non-reversing - low torque starting	1	1 1/2	2
U	Uneven load - 8 hour/day service* Moderate shock or torsional loads - Non reversing - This is the most common type of service.	1 1/2	2	2 1/2
H	Heavy shock load - 8 hour/day service* High peak torsional loads - Reversing under load - Full load starting.	2	2 1/2	3

* For 16 to 24 hour/day service use service factor for next higher class loading.
Note—For even load, stand by, seasonal or infrequent service the normal service rating of the coupling will determine its proper selection.

COUPLING SELECTION INFORMATION:

Application information: A finished bore chain coupling is required to drive a pulp grinder (1 3/4" shaft) from a 1800 RPM, 20 HP electric motor (1 5/8" shaft) approximately 16 hours per day.

1. Determine load classification and service factor.

Note that a pulp grinder is considered a Class "U" load but since it is to operate 16 hours per day, it must be classed as an "H" load. Table No. 13 indicates that the service factor for a Class H load driven by an electric motor is 2.

2. Calculate the required horsepower. Input Horsepower (20) x Service Factor (2) = Required Horsepower (40).

3. Determine the Coupling Size. From Table No. 9, Page 189, select the smallest coupling for 1800 RPM that meets the horsepower requirements. Verify bore requirements (1 5/8" driver, 1 3/4" driven) for selected hub size. Select C5018 based on shaft requirements.

MISALIGNMENT

For maximum life, angular misalignment should not exceed 1/2". Refer to sketch to insure that .009 inches per inch of root diameter is not exceeded. This is equivalent to 1/2° of angular misalignment. Offset or parallel misalignment not to exceed 2% of chain pitch is recommended.

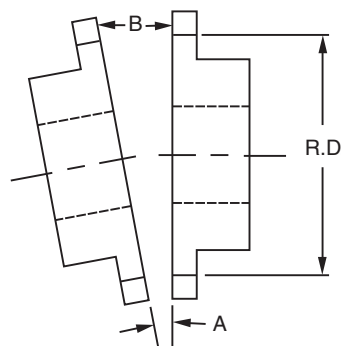

$$B-A = .009" \times R.D.$$